

TERRA DX 5 HCUA

MONOVALENT HEATING SYSTEM WITH GROUND AS HEAT SOURCE

ORDER NUMBER: 277010

SERIES: M2

TF MAX. 65 °C

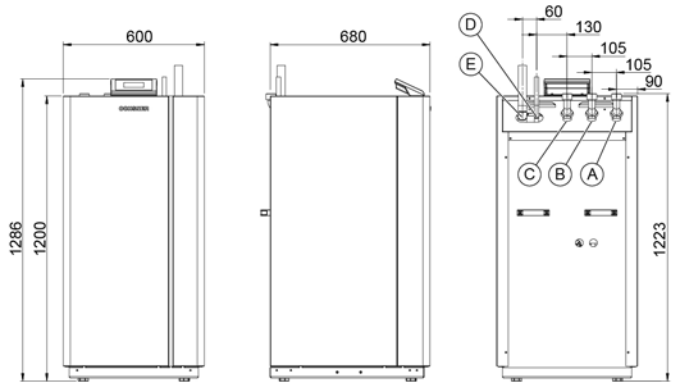

(A) FLHC (outlet) (B) FLT (outlet) (C) RTN (inlet) (D) WQA (outlet) (E) WQA (inlet)

APPLIANCE DATA

Dimensions HxWxD	[mm]	1285x600x681
Hydraulic connection	[inch]	1 1/4"
Weight	[kg]	185
Casing colour		White/anthracite

SPECIFICATION

Phases/nominal voltage/frequency	[~]/[V]/[Hz]	3/400/50
Output factor cos φ		0,70
Fuse protection (tripping curve "C")	[A]	10
Max. operating current	[A]	4,00
Max. starting current/max. with soft start	[A]	27.00 / 13.50
Sound power level/sound pressure level (at 1 m distance)	[dBA]	41.30 / 33.30

HEATING MODE PERFORMANCE FIGURES (to EN 14511)

Standard point E4/W35		
Heating output	[kW]	6,20
Total power consumption / operating current	[kW]/[A]	1.30 / 2.80
COP		4,80
Operating point E-1/W35		
Heating output	[kW]	5,20
Total power consumption / operating current	[kW]/[A]	1.30 / 2.80
COP		4,10
Operating point E0/W50		
Heating output	[kW]	4,90
Total power consumption / operating current	[kW]/[A]	1.70 / 3.10
COP		2,90
Operating point E0/W60		
Heating output	[kW]	4,70
Total power consumption / operating current	[kW]/[A]	2.20 / 3.80
COP		2,10

CONDENSER

Type		Plate heat exchanger
Material		Stainless steel 1.4301
Max. refrigerant operating pressure	[bar]	30
Max. heat transfer medium operating pressure	[bar]	6
Heat transfer medium temperature differential	[K]	5
Application range	[°C]	65
Heat transfer medium		Water
Test pressure	[bar]	45
Heat transfer medium flow rate	[m³/h]	1,07
Internal pressure differential	[mbar]	197
Flow meter (FM)	Internal	Installed as
Circulation pump heat sink (WNA)	Internal	Yonos Para HPS 25/7.5
Residual head WNA external	[mbar]	569

REFRIGERANT CIRCUIT

Refrigerant		R407C
Refrigerant charge (from-to)	[kg]	3,4-5,5

COMPRESSOR

Type		Scroll
Output levels		1
Speed	[rpm]	2900
Voltage/frequency	[V]/[Hz]	400 / 50

EVAPORATOR

Type		Tube evaporator
No. of circuits (recommended)	[pce]	(3*) 4
No. of circuits (max.)	[pce]	5
Length per circuit	[m]	75
Material		Copper / seamless PE outer casing
Max. refrigerant operating pressure	[bar]	30

Hydraulic version		Electric immersion heater		3-way switching module	
		Internal	external	Internal	external
M2-1	M4-1	x		x	
M2-2	M4-2		x	x	
M2-3	M4-3	x			x
M2-4	M4-4		x		x

*Number of circuits possible for optimum soil conditions: cohesive soil/moist or better at max. 1800 h/a



Geothermal collector:

The geothermal collectors O-Tube Pro are filled at the factory with nitrogen and each have a leakage indicator, which enables simple leakage monitoring during routing right up to the checks prior to commissioning. A collector array may not be built on and must be laid with a minimum clearance of 1.5 m to building components and property boundaries. The minimum spacing for collector pipes is 0.5 m. A routing plan of the individual collector circuits based on the actual routing is required for commissioning. The individual collector pipe ends of the collector circuits must be labelled.



RECOMMENDED ACCESSORIES

	Order no./type	Description	Pressure loss
Heat pump separating cylinders	min. PU200	30 l/kW at G-1/W50	-
DHW tank	min. SP300/SP350	30 l/kW at E0/W50	-
External plate heat exchanger (DHW heating)	911251 PHE 2007	Prim.: 1" Sec.: 1"	Prim.: 34 mbar Sec.: 71 mbar
3-way switching module internal	980196	-	-
3-way switching module external	290229	DN32 (1 1/4"). kvs 16	4 mbar
Electric immersion heater internal	980197	8.8 kW (2.9 / 2.9 / 2.9)	-
External electric immersion heater (heat pump buffer tank)	922507	3 kW	-
Copper geothermal collector (O-Tube Pro)	913209	75 m per unit	-

REQUIRED

EXTRACTION SURFACE

Basic cooling capacity (at E4/W35)	[kW]	4.9
Extraction surface (at 1800 h/a)	[m ²]	196
Extraction surface (at 2400 h/a)	[m ²]	245
Max. connection length to collection shaft	[lm]	20

CONDITIONS IN ACC. WITH VDI 4640 OR ÖWAV 207

Soil conditions	Max. spec. extraction capacity at 1800 h/a	Max. spec. extraction capacity at 2400 h/a
Dry, non-cohesive soil	10 W/m ² and 5 W/lm	8 W/m ² and 4 W/lm
Cohesive soil, moist	20-30 W/m ² and 15 W/lm	16-24 W/m ² and 12 W/lm
Water-saturated soil, sand/gravel	40 W/m ² and 20 W/lm	32 W/m ² and 16 W/lm

PERFORMANCE CURVES TERRA DX 5 HCUA

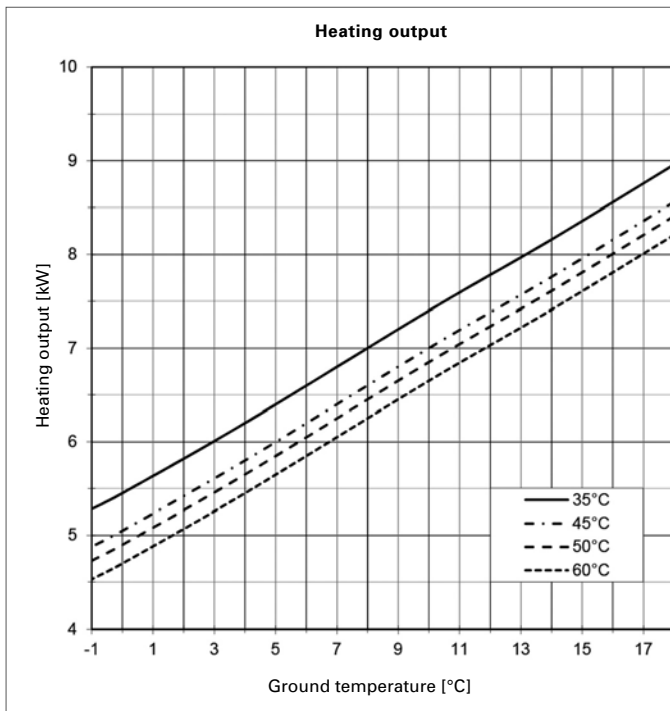

PRODUCT DATA ErP: TERRA DX 5 HCUA

	COLDER	MEAN	HOTTER
LOW TEMPERATURE A++		35°C	
ηs	207	197	194
Energy consumption [kWh]	2848	2496	1642
P rated [kW]	6	6	6
SCOP	5,37	5,13	5,05
MEDIUM TEMPERATURE A++		55°C	
ηs	136	131	129
Energy consumption [kWh]	3842	3337	2191
P rated [kW]	6	6	6
SCOP	3,59	3,47	3,42
DHW A		SP300	
ηWH	88	88	88
Energy consumption [kWh]	1622	1622	1622
Draw-off profile		XL	
Tank losses [W]		94	
		indoor	outdoor
Sound power level [dBA]		41,3	-
Controller class with room remote control	VII	Controller contribution [%]	3,5
Controller class without room remote control	III	Controller contribution [%]	1,5

