

# TERRA 8 HPLA

## MONOVALENT HEATING SYSTEM WITH BRINE AS HEAT SOURCE

ORDER NUMBER: 265020

SERIES: M2

TF MAX. 65 °C

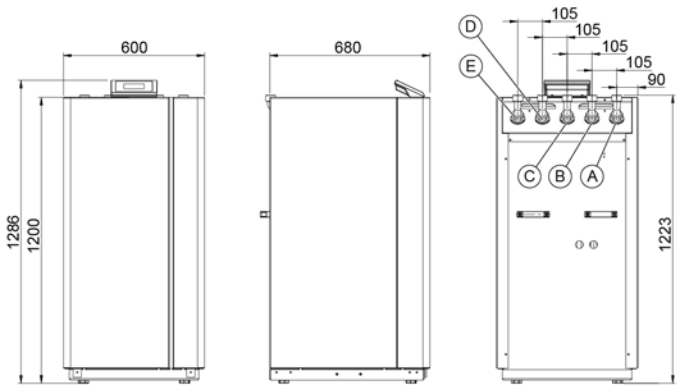

(A) FLHC (outlet) (B) FLT (outlet) (C) RTN (inlet) (D) WQA (outlet) (E) WQA (inlet)

### APPLIANCE DATA

Dimensions HxWxD	[mm]	1285x600x681
Hydraulic connection	[inch]	1 1/4"
Weight	[kg]	210
Casing colour		White/anthracite

### SPECIFICATION

Phases/nominal voltage/frequency	[~]/[V]/[Hz]	3/400/50
Output factor cos φ		0,86
Fuse protection (tripping curve "C")	[A]	16
Max. operating current	[A]	6,20
Max. starting current/max. with soft start	[A]	43.00 / 21.50
Sound power level/sound pressure level (at 1 m distance)	[dBA]	44.00 / 36.00

### HEATING MODE PERFORMANCE FIGURES (to EN 14511)

Standard point B0/W35		
Heating output	[kW]	7,50
Total power consumption / operating current	[kW]/[A]	1.55 / 2.60
COP		4,80
Operating point B0/W50		
Heating output	[kW]	6,80
Total power consumption / operating current	[kW]/[A]	2.30 / 3.90
COP		3,00
Operating point B0/W60		
Heating output	[kW]	6,20
Total power consumption / operating current	[kW]/[A]	2.50 / 4.40
COP		2,50

### CONDENSER

Type		Plate heat exchanger
Material		Stainless steel 1.4301
Max. refrigerant operating pressure	[bar]	45
Max. heat transfer medium operating pressure	[bar]	6
Heat transfer medium temperature differential	[K]	5
Application range	[°C]	65
Heat transfer medium		Water
Test pressure	[bar]	54
Heat transfer medium flow rate	[m³/h]	1,29
Internal pressure differential	[mbar]	264
Flow meter (FM)	Internal	Installed as
Circulation pump heat sink (WNA)	Internal	Yonos Para HPS 25/7.5
Residual head I WNA external	[mbar]	496

### REFRIGERANT CIRCUIT

Refrigerant		R410A
Refrigerant charge	[kg]	1,9

### COMPRESSOR

Type		Scroll
Output levels		1
Speed	[rpm]	2900
Voltage/frequency	[V]/[Hz]	400/50

### EVAPORATOR

Type		Plate heat exchanger
Material		Stainless steel 1.4301
Number	[pce]	1
Max. heat transfer medium operating pressure	[bar]	6
Max. refrigerant operating pressure	[bar]	12
Heat transfer medium temperature differential	[K]	3
Application range	[°C]	-5/+20
Heat transfer medium		Brine max. 30%
Test pressure	[bar]	54
Heat transfer medium flow rate	[m³/h]	1,87
Internal pressure differential	[mbar]	-
Flow meter (FM)	Internal	Installed as
Circulation pump heat source (WQA)	Internal	Stratos Para 25/1-8
Residual head I WQA external	[mbar]	579

Hydraulic version			Electric immersion heater		3-way switching module	
			Internal	external	Internal	external
M2-1	M4-1		x		x	
M2-2	M4-2			x	x	
M2-3	M4-3		x			x
M2-4	M4-4	M6		x		x

**RECOMMENDED ACCESSORIES**

	Order no./type	Description	Pressure loss
Heat pump separating cylinders	min. PU300	min. PU300	-
DHW tank	min. SP300/SP350	30 l/kW at B0/W50	-
External plate heat exchanger (DHW heating)	911251 PHE 2007	Prim.: 1" Sec.: 1"	Prim.: 63 mbar Sec.: 72 mbar
3-way switching module internal	980196	-	-
3-way switching module external	290229	DN32 (1 1/4"). kvs 16	7 mbar
Electric immersion heater internal	980197	8.8 kW (2.9 / 2.9 / 2.9)	-
External electric immersion heater (heat pump buffer tank)	922508	6 kW	-
Brine collector set (shallow laying)	290167	ESK 4	Pressure loss 61 mbar incl. brine distributor

**EXTRACTION CAPACITY ACC. TO VDI 4640**

**FOR SHALLOW LAYING**

Soil conditions	Max. spec. extraction capacity at 1800 h/a	Max. spec. extraction capacity at 2400 h/a
Dry, non-cohesive soil	10 W/m <sup>2</sup>	8 W/m <sup>2</sup>
Cohesive soil, moist	25 W/m <sup>2</sup>	20 W/m <sup>2</sup>
Water-saturated soil with sand/gravel	40 W/m <sup>2</sup>	32 W/m <sup>2</sup>

**FOR DEEP TRENCH LAYING**

Soil conditions	Max. spec. extraction capacity at 1800 h/a
Cohesive soil, moist	100 W/m deep trench
Water-saturated soil	125 W/m deep trench

**FOR GEOTHERMAL PROBES**

Soil conditions	Spec. extraction capacity at 1800 h/a	Max. spec. extraction capacity at 2400 h/a
Dry sediment	25 W/m	20 W/m
Shale, slate	45 W/m	35 W/m
Firm rock with high thermal conductivity	84 W/m	70 W/m
Substratum with high groundwater flow	65-80 W/m	55-65 W/m

**SIZING RECOMMENDATION WITH BRINE AS HEAT SOURCE**

Pressure loss in connection line, incl. individual losses	Max. 100 mbar
Pressure loss in brine circuits or probes, incl. brine distributor	Max. 300 mbar

**PERFORMANCE CURVES TERRA 8 HPLA**

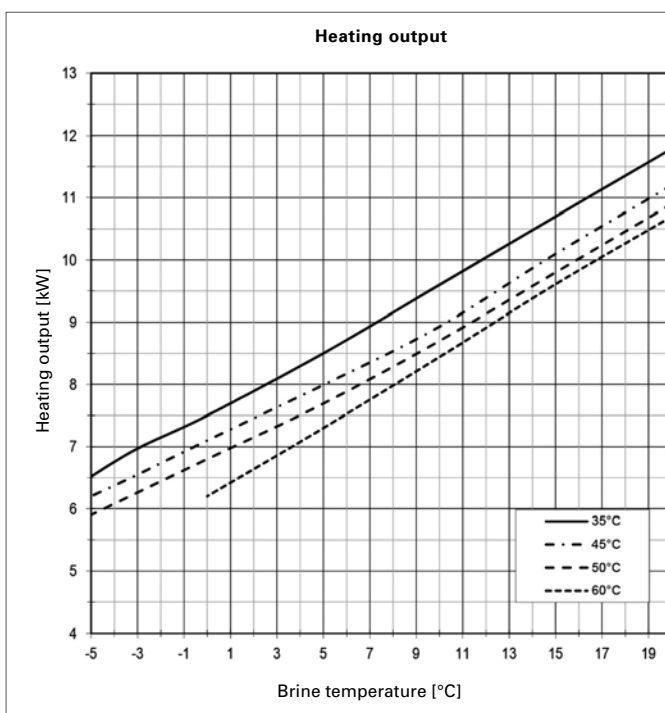

**PRODUCT DATA ErP: TERRA 8 HPLA**

		COLDER	MEAN	HOTTER
<b>LOW TEMPERATURE</b>	<b>A++</b>		<b>35°C</b>	
ηs		228	216	214
Energy consumption	[kWh]	3134	2772	1806
P rated	[kW]	8	8	8
SCOP		5,90	5,59	5,55
<b>MEDIUM TEMPERATURE</b>	<b>A++</b>		<b>55°C</b>	
ηs		133	127	126
Energy consumption	[kWh]	4735	4125	2689
P rated	[kW]	7	7	7
SCOP		3,51	3,38	3,35
<b>DHW</b>	<b>A</b>		<b>SP300</b>	
ηWH		82	82	82
Energy consumption	[kWh]	1733	1733	1733
Draw-off profile			<b>XL</b>	
Tank losses	[W]		<b>94</b>	

		indoor	outdoor
Sound power level	[dBA]	44,0	-
Controller class with room remote control		VII	Controller contribution [%] 3,5
Controller class without room remote control		III	Controller contribution [%] 1,5

