

EUROPA 323 DK

Multifunctional appliances

Air / Exhaust air heat pump with 300l tank

- » Series: Europa
- » Compact appliance with 300l tank
- » tww max. 65°C
- » Order number: 110261

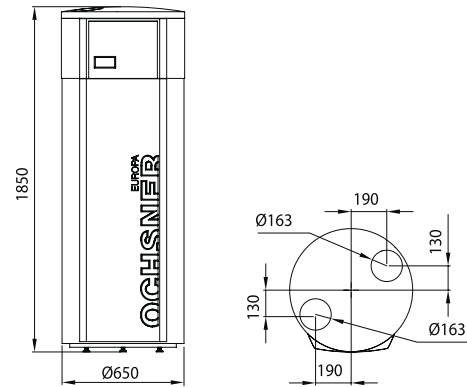

Appliance data:

Dimensions (diameter x height)	[mm]	650 x 1850
Type		compact
Weight	[kg]	165
Control electronic		Tiptronic plus with Touch Display
COP EN255-3/EN16147		3,5/3,15
Housing colour		tiger white 29/11289/grey RAL 7016

Technical data:

Phases/Nominal voltage/Frequency	[~]/[V]/[Hz]	1/230/50
cos φ		0,75
Fuse (trip characteristic °C)	[A]	16
Max. operating current	[A]	4
Start-up current	[A]	16,5
Sound power level/sound pressure level (in 1m)	[dBA]	57/49

Performance data:

Operating point A21/W15-55

Heating capacity	[kW]	2,2
Power consumption	[kW]	0,5
COP		4,4

Operating point A15/W15-55

Heating capacity	[kW]	1,95
Power consumption	[kW]	0,49
COP		4

Hot water storage tank:

Nominal volume	[l]	300
Permitted operating pressure	[bar]	6
Material		steel enamelled
Insulation	[kW]	PU hard foam
Protecting anode		2 pce. 1* Magnesium
Max. temperature Solar operation	[°C]	65

Electric auxiliary heater:

Type		immersion heat exchanger
Quantity	[piece]	1
Heating capacity	[kW]	1,5

Auxiliary heater register:

Type		smooth tube 3/4"
Permitted operating pressure	[bar]	4
Permitted operating temperature of the heating agent	[°C]	90
Register area	[m²]	1,4

Condenser:

Type		finned-tube heat exchanger
Material		copper
Quantity	[piece]	1
Max. operating pressure refrigerant	[bar]	25
Max. operating pressure working fluid	[bar]	6
Operating range	[°C]	65
Working fluid		water
Testing pressure	[bar]	45

Refrigerant circuit:

Number of circuits	[piece]	1
Refrigerant		R 134a
Refrigerant filling	[kg]	0,66

Compressor:

Type		fully hermetic/rolling piston
Quantity	[piece]	1
Power stages		1
Start-up type		direct
Voltage/Frequency	[V]/[Hz]	230/50

Fan:

Type		Radial fan
Quantity	[piece]	1
Voltage/Frequency	[V]/[Hz]	230/50
Power consumption	[W]	68
Max. operating current	[A]	1,4
Air flow rate free blowing	[m³/h]	510-360
Continuous stage controlled		integrated
External pressure	[Pa]	80

Evaporator:

Type		air/finned tube
Material		Cu Al
Quantity	[piece]	1
De-icing technology / frost protection switch-off		hot gas
Max. operating pressure refrigerant	[bar]	25
Operating temperature min.	[°C]	-10
Operating temperature max.	[°C]	+40

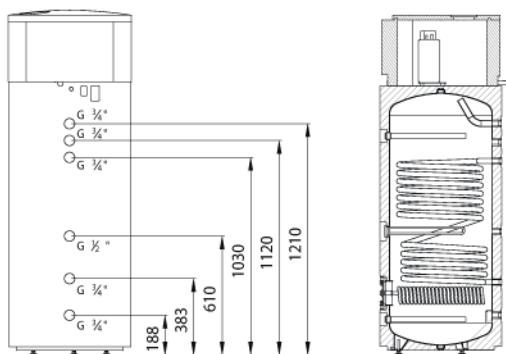

- Control electronic Tiptronic plus with Touch Display**
for simple control of:
- selectable hygiene comfort switching
 - real time clock
 - rotation speed regulation and timer program for fan function
 - de-icing function for deployment down to -10°C
 - incl. solar regulation for solar thermal system (not supplied)
 - Smart Grid Function

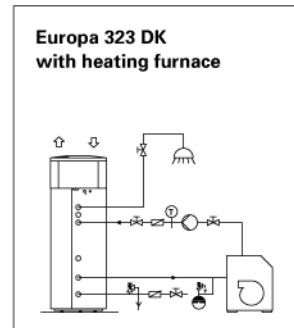
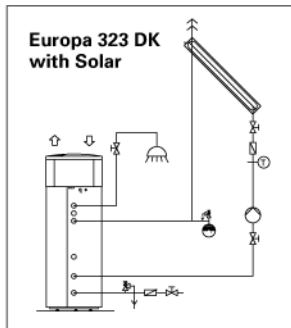

EXAMPLES OF USE



Exhaust system (single duct ventilation), exhaust air: from bathroom, WC, kitchen Air exit to outside free air

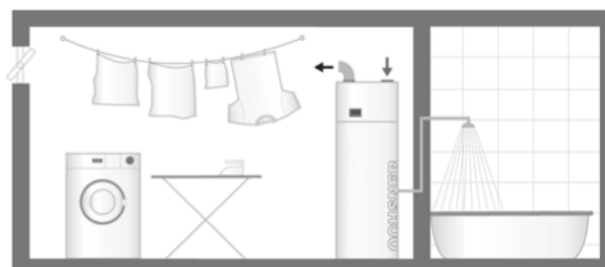

Installation in laundry room
Hot water heating with room air, dehumidification of the room

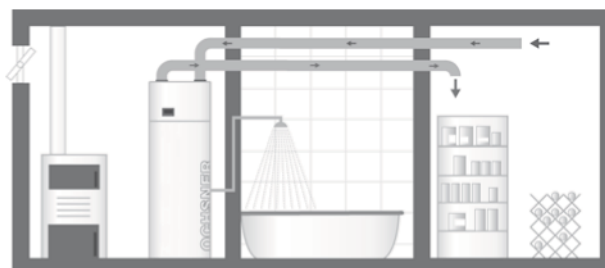

Pantry cooling

Performance curves Europa 323 DK:

